

MODEL GO1700E
SPEED INCREASER

Model GO1700E is a heavy duty independently mounted speed increaser having engine rotation. The gears are helical, carburized and precision ground for increased strength and quiet operation. The bearings are tapered roller. The case is stress relieved, fabricated steel.

Text

| | |
|--------------------------|--|
| CAPACITY: | 5500 ft.lbs. |
| MAXIMUM INPUT SPEED: | 2500 RPM |
| MAXIMUM OUTPUT SPEED: | 5500 RPM |
| RATIOS: | 1.27, 1.68, 2.0, 2.26, 2.57, 2.75, 2.95 |
| INPUT HOUSINGS: | SAE #0, #00 |
| INPUT CLUTCH: | Overcenter type clutches, rubber block drives or couplings to fit various engines. |
| OUTPUT SHAFT: | 2.750" diameter x 6.0" long with 5/8W x 15/16D keyway. |
| OUTPUT SHAFT LOCATIONS: | 12 o'clock- output is above input 6 o'clock- output is below input 9 o'clock- output is to left of input |
| LUBRICATION REQUIREMENT: | Lube pump furnished for oil spray on bearings and gears. |
| COOLING: | Heat exchanger furnished |
| ACCESSORIES FURNISHED: | Oil level sight gauge, filter, temperature/pressure switch relief valve |
| OPTIONS: | Stub input shaft 4.000" diameter x 6" long 1" W x 1/2D |
| WEIGHT: | 1900 lbs |

07/31/03

MODEL GO1700E

SPEED INCREASER

| BELLHSG SAE # | DIM A |
|------------------|-------|
| #1 | 15.00 |
| #0 | 16.25 |
| #0 DEEP | 18.50 |
| #00 | 16.25 |
| #00 DEEP | 20.50 |

MODEL ALSO AVAILABLE WITH OUTPUT
AT 3, 6, OR 9 O'CLOCK POSITION
CONTACT COTTA FOR MORE INFORMATION

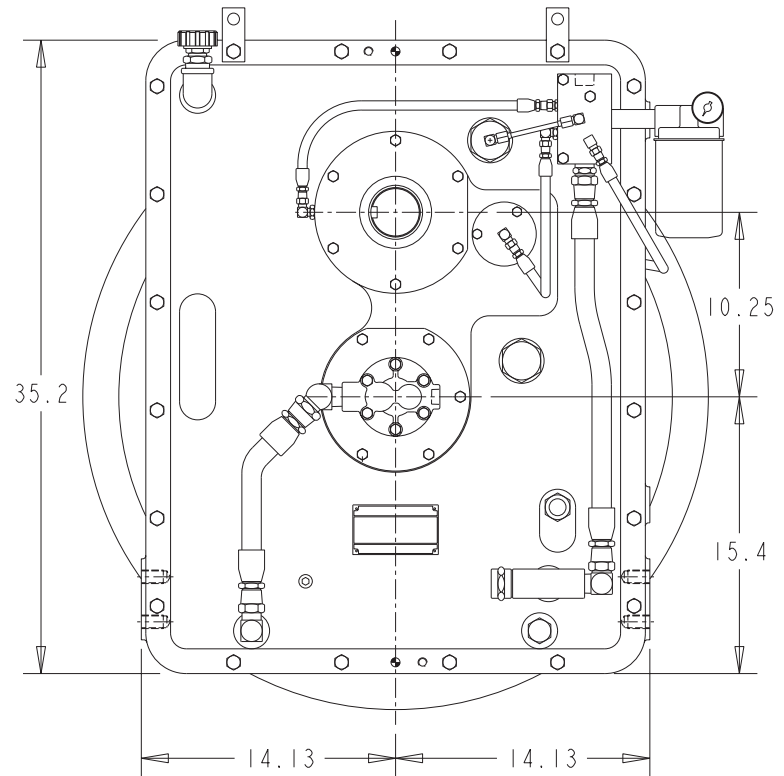
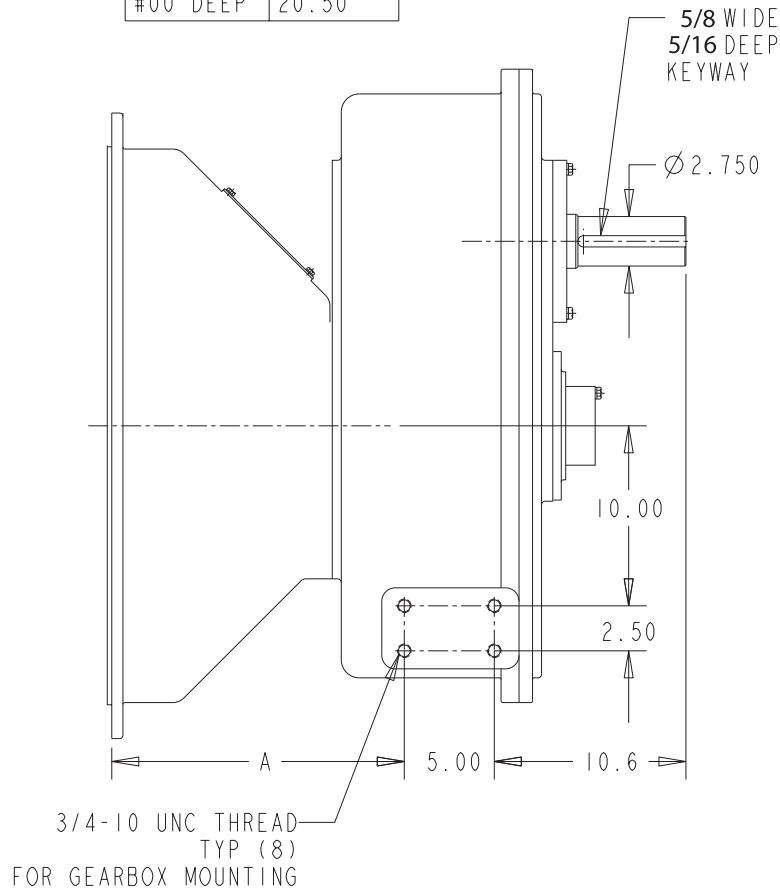

DO NOT USE DIMENSIONS ON THIS DRAWING FOR
INSTALLATIONS, USE CERTIFIED PRINT PROVIDED
WITH ORDERS.