

MODEL SI3A
SPEED INCREASER

Model SI3A is a heavy duty unit mounted speed increaser having anti-engine rotation. It is available with a variety of input housings and clutches (or rubber block drives or flywheel couplings) to fit the different engines. A wide range of ratios are offered.

The gears are helical, carburized and precision ground and are per AGMA Q-12. The bearings are taper roller throughout. The case is heavy cast iron.

CAPACITY (nominal input torque):	2000 lb. ft.
MAXIMUM INPUT SPEED:	3000 RPM NOTE: with SP218 clutch - 2000 RPM with SP318 clutch - 2350 RPM
MAXIMUM OUTPUT SPEED:	6000 RPM
RATIOS:	1.39, 1.50, 1.66, 2.0, 2.21, 2.44, 3.04
BELL HOUSINGS:	SAE #0, #1
CLUTCHES:	SP314, SP218, SP318 and 14" and 18" rubber block drives
OUTPUT SHAFT:	2.750" diameter with 5/8 x 5/16 keyway
REAR SUPPORT:	4 holes 5/8-11 on rear cover for customers support plate
LUBRICATION:	ISO Viscosity Grade 68 Lube pump and filter furnished
COOLING:	Heat exchanger is furnished (loose)
WEIGHT:	1000 lbs

Note: The output shaft can be located at 6 o'clock (below the input shaft) or at the 12 o'clock (above the input shaft) positions.

07/31/03

MODEL SI3A SPEED INCREASER

BELLHSG SAE #	DIM A
#1	22.75
#0	26.25

OUTPUT CAN BE ORIENTED
AT 3, 6, 9, OR 12 O'CLOCK POSITION
CONTACT COTTA FOR MOUNTING HOLE LOCATION

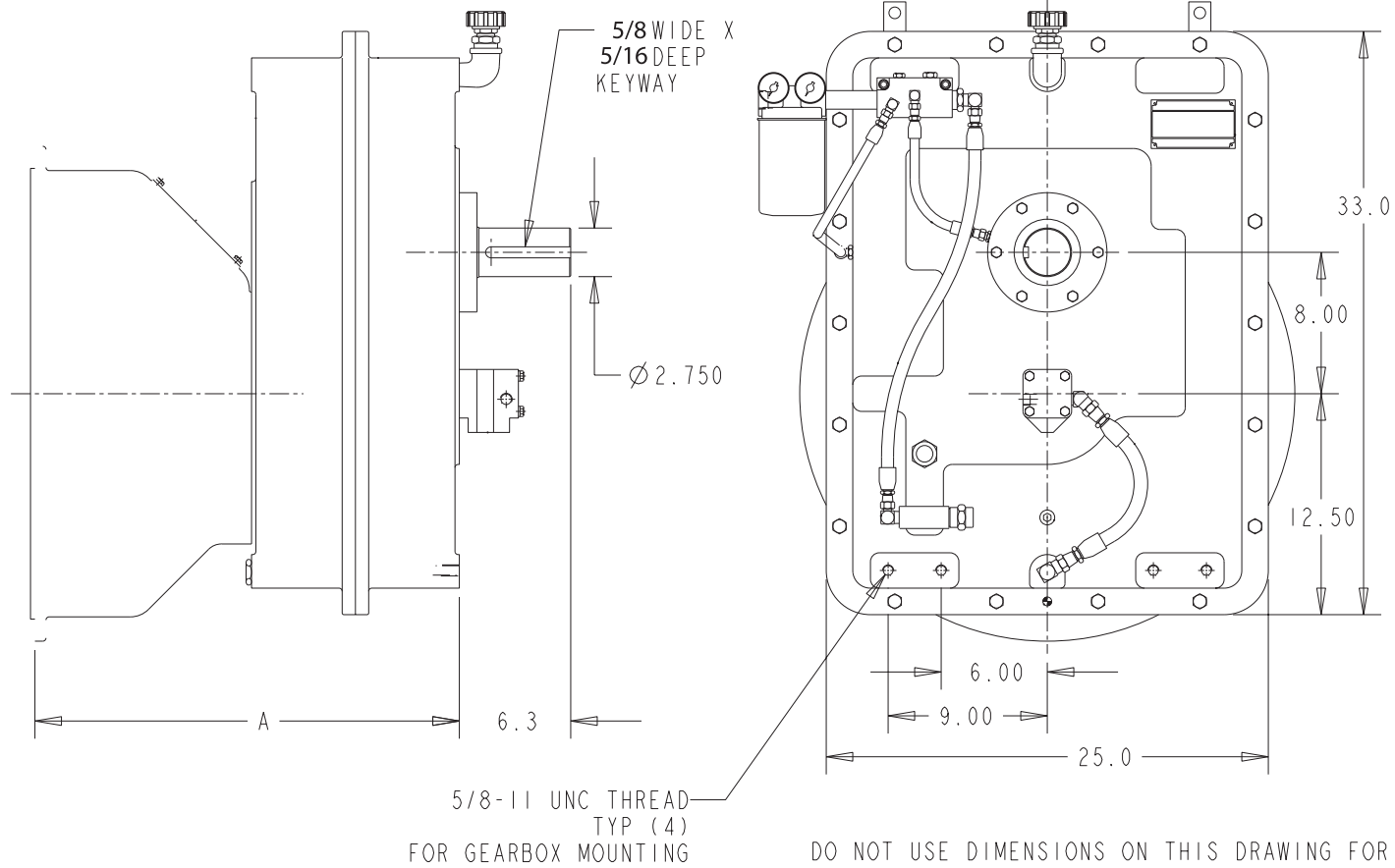

DO NOT USE DIMENSIONS ON THIS DRAWING FOR
INSTALLATIONS, USE CERTIFIED PRINT PROVIDED
WITH ORDERS.