



# MODEL AR2053A

## SPEED REDUCER

### Product Description

Model AR2053A is a single-stage reduction gearbox designed for direct mounting to industrial engines via an SAE flange and driven in standard engine rotation (CW facing input shaft). Tabulated below are nominal power and speed capacity together with standard options. Contact Cotta to discuss other options or specialized requirements.

<b>OUTPUT ROTATION:</b>	Opposite input
<b>MAX INPUT TORQUE:</b>	500 lb-ft.
<b>MAX INPUT SPEED:</b>	3000 rpm or as otherwise limited by input coupling or clutch.
<b>RATIOS:</b>	1.0 to 3.0 std. 3.94 by special order
<b>OUTPUT SHAFT SIZE:</b>	2.25" dia., X 5" long. 5/8" X 5/16" keyway
<b>OUTPUT SHAFT LOCATION:</b>	6 o'clock std, 12, 3, and 9 o'clock optional
<b>SAE HOUSINGS:</b>	#2, #3, #4
<b>*FLYWHEEL COUPLINGS:</b>	Clutches, couplings, and drive plates up to SAE 11".
<b>REAR SUPPORT:</b>	Required. Customer supplied item. Mounting holes provided per dwg.
<b>LUBRICATION:</b>	Splash standard, pump optional.
<b>COOLING:</b>	Oil/water shell-and-tube cooler furnished if required. Various options.
<b>**SIDE LOAD CAPABLE:</b>	No. Contact Cotta for recommendations.
<b>***APPROXIMATE WEIGHT:</b>	400 lbs.

\* Flywheel coupling selection requires Cotta technical review and approval.

\*\* Some speed reducers output shafts are suitable for chain or belt side pull drives while others are not. Provide complete application details to Cotta for recommendations and approval.

\*\*\* Weight listed is an average. Actual weight can vary substantially with options such as SAE housing size and flywheel coupling choices.



This drawing shows general arrangement and approximate space claim. Do not design or lay out using this drawing. Use only certified drawings provided by Cotta Engineering.

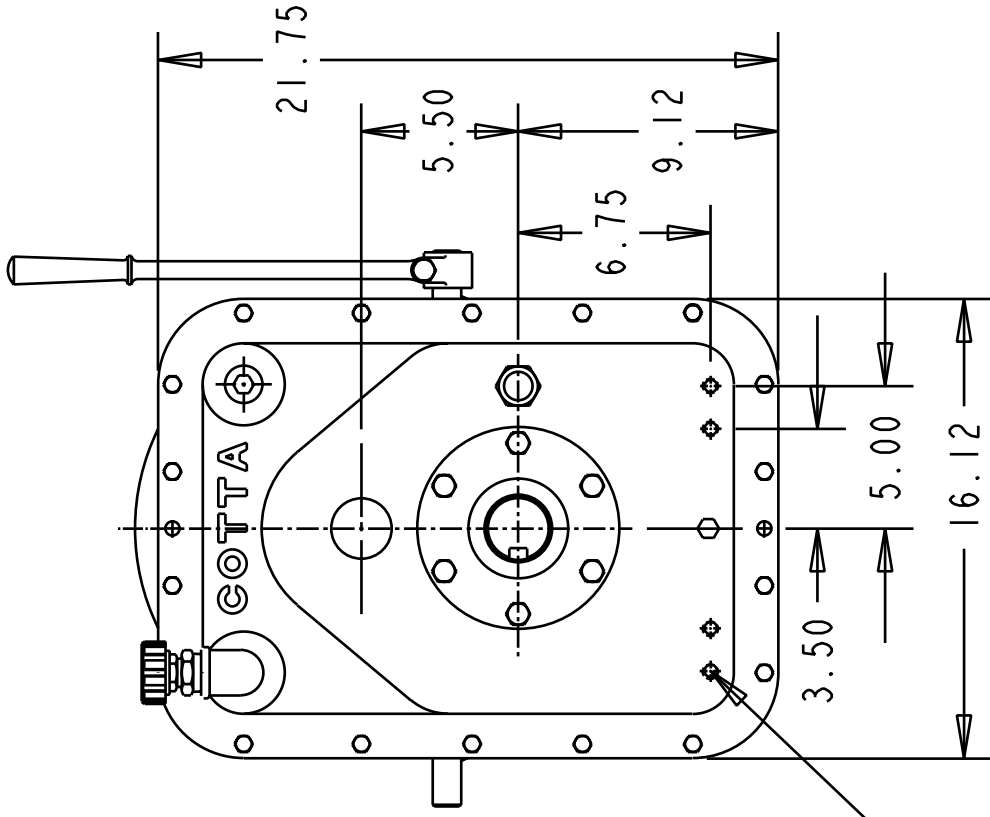
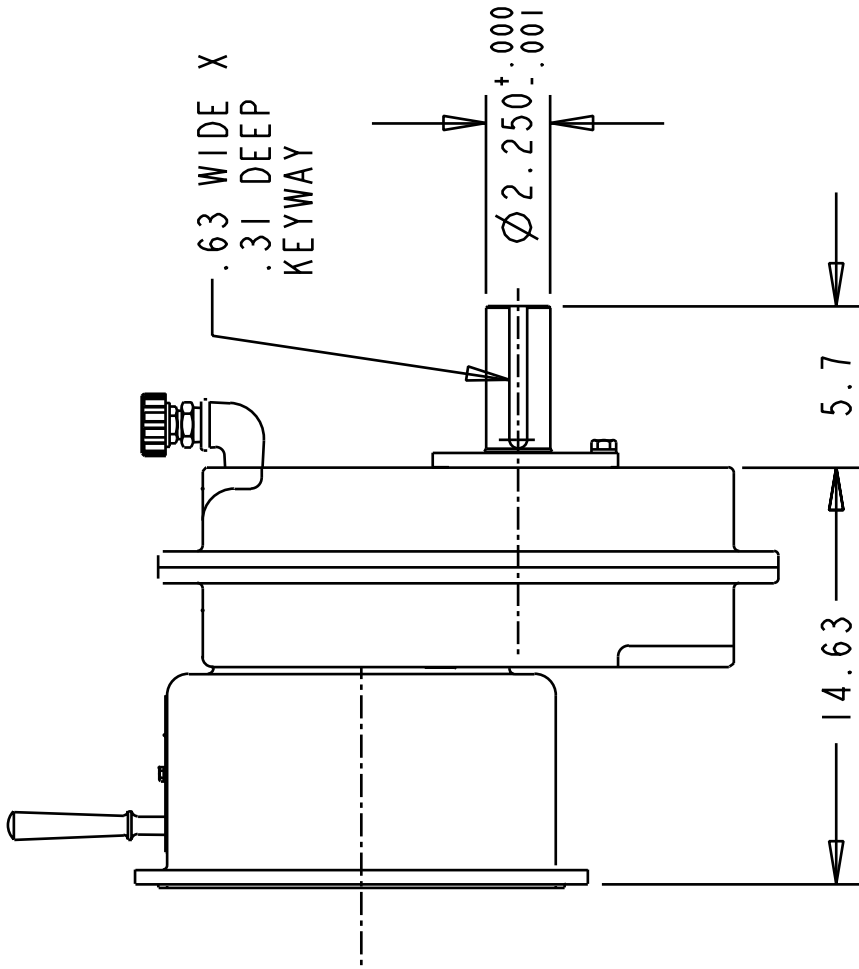

1/2-13 UNC THREAD  
TYP (4)  
FOR GEARBOX MOUNTING

# AR2053A DRAWING