



# MODEL GR975200 SPEED REDUCER

## Product Description

Model GR975200 is a two-stage reduction gearbox designed for direct mounting to industrial engines via an SAE flange and driven in standard engine rotation (CW facing input shaft). Tabulated below are nominal power and speed capacity together with standard options. Contact Cotta to discuss other options or specialized requirements.

<b>OUTPUT ROTATION:</b>	Same as input.
<b>MAX INPUT TORQUE:</b>	2400 lb-ft.
<b>MAX INPUT SPEED:</b>	2200 RPM or as otherwise limited by input clutch or coupling.
<b>RATIOS:</b>	3.49 to 6.58.
<b>OUTPUT SHAFT SIZE:</b>	5.5" dia., 8" long, with 1.0" X .5" keyway.
<b>OUTPUT SHAFT LOCATION:</b>	6 o'clock std, 12, 3, and 9 o'clock optional
<b>SAE HOUSINGS:</b>	#00, #0, #1
<b>*FLYWHEEL COUPLINGS:</b>	Various clutches, couplings, and drive plates through SAE 24".
<b>REAR SUPPORT:</b>	Required. Customer supplied item. Mounting holes provided per drawing.
<b>LUBRICATION:</b>	Integral Lube pump supplied
<b>COOLING:</b>	Oil/water shell-and-tube furnished if required. Various options.
<b>**SIDE LOAD CAPABLE:</b>	No. Contact Cotta for recommendations.
<b>***APPROXIMATE WEIGHT:</b>	2300 lbs.

\* Flywheel coupling selection requires Cotta technical review and approval.

\*\* Some speed reducers output shafts are suitable for chain or belt side pull drives while others are not. Provide complete application details to Cotta for recommendations and approval.

\*\*\* Weight listed is an average. Actual weight can vary substantially with options such as SAE housing size and flywheel coupling choices.



This drawing shows general arrangement and approximate space claim. Do not design or lay out using this drawing. Use only certified drawings provided by Cotta Engineering.

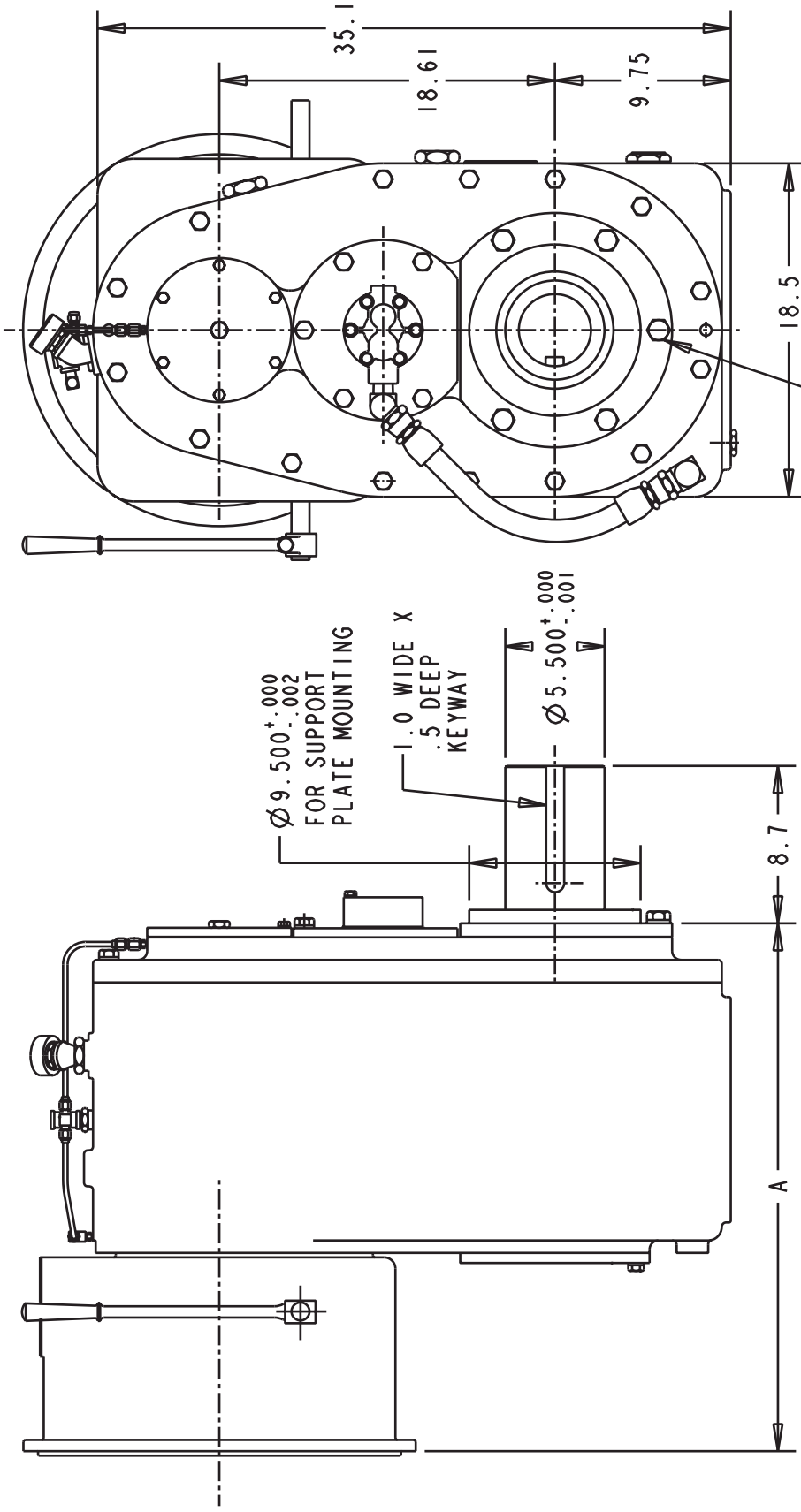

BELLHSG SAE#	DIM A
#1 & #1/2	30.0
#0 & #00	32.75
#1 & #1/2 (DEEP)	31.5
#0 (DEEP)	35.0

3/4-10 UNC CAPSCREW  
(5) ON A (6) EQ  
SPACED  $\text{Ø} 11.500$  BC  
FOR SUPPORT  
PLATE MOUNTING

# GR975200 DRAWING