



MODEL SI3A

SPEED INCREASER

Product Description

Model SI3A is a single-stage increasing gearbox designed for direct mounting to industrial engines via an SAE flange and driven in standard engine rotation (CW facing input shaft). Tabulated below are nominal power and speed capacity together with standard options. Contact Cotta to discuss other options or specialized requirements.

OUTPUT ROTATION:	Opposite to input.
MAX INPUT TORQUE:	2000 lb-ft.
MAX INPUT SPEED:	3000 RPM or as otherwise limited by input clutch or coupling.
MAX OUTPUT SPEED:	5500 RPM
RATIO RANGE:	1.27 to 2.44
OUTPUT SHAFT SIZE:	2.750" diameter with 5/8" X 5/16" keyway.
OUTPUT SHAFT LOCATION:	12 o'clock std. 3, 6, and 9 o'clock optional.
SAE FLANGE OPTIONS:	#0, #1
*FLYWHEEL COUPLINGS:	Various clutches, couplings, and drive plates through SAE 18".
REAR SUPPORT:	Required. Customer supplied item. Mounting holes provided per drawing.
LUBRICATION:	Integral Lube pump supplied
COOLING:	Oil/water shell-and-tube cooler furnished if required. Various options.
**SIDE LOAD CAPABLE:	No. Contact Cotta for recommendations.
***APPROXIMATE WEIGHT:	1000 lbs.

* Flywheel coupling selection requires Cotta technical review and approval.

** Cotta Speed Inserter output shafts are not designed for belt or chain side pull drives. If your application requires side loads provide complete application details to Cotta for recommendations and approval.

*** Weight listed is an average. Actual weight can vary significantly with options such as SAE housing size and flywheel coupling choices.



This drawing shows general arrangement and approximate space claim. Do not design or lay out using this drawing. Use only certified drawings provided by Cotta Engineering.

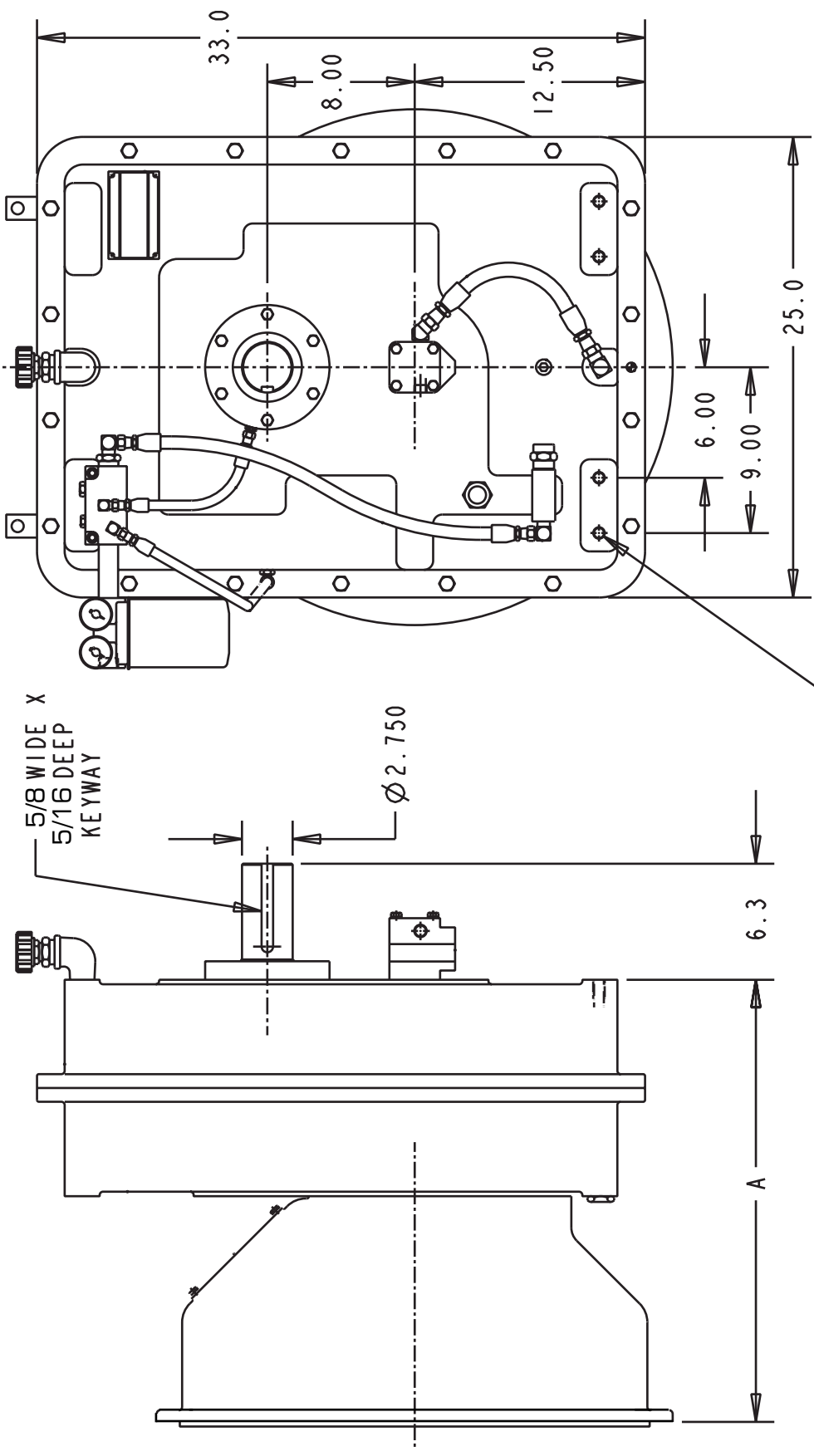

5/8 WIDE X
5/16 DEEP
KEYWAY

Ø 2.750

6.3

A

5/8-11 UNC THREAD
TYP (4)
FOR GEARBOX MOUNTING

BELLHSG SAE #	DIM A
#1	22.75
#0	26.25

SI3A DRAWING