



MODEL SR2030E

SPEED REDUCER

Product Description

Model SR2030E is a single-stage reduction gearbox designed for direct mounting to industrial engines via an SAE flange and driven in standard engine rotation (CW facing input shaft). This unit incorporates an idler shaft to provide output rotation same as input. Tabulated below are nominal power and speed capacity together with standard options. Contact Cotta to discuss other options or specialized requirements.

OUTPUT ROTATION:	Same as input.
MAX INPUT TORQUE:	750 lb-ft.
MAX INPUT SPEED:	2500 RPM or as otherwise limited by input clutch or coupling.
RATIOS:	3.22 to 5.20
OUTPUT SHAFT SIZE:	3.500" dia., 5.5" long 7/8" X 7/16" keyway.
OUTPUT SHAFT LOCATION:	6 o'clock std, 12, 3, and 9 o'clock optional
SAE HOUSINGS:	#0, #1, #2, #3
*FLYWHEEL COUPLINGS:	Various clutches, couplings, and drive plates through SAE 18".
REAR SUPPORT:	Required. Customer supplied item. Mounting holes provided per drawing.
LUBRICATION:	Integral Lube pump supplied.
COOLING:	Oil/water shell-and-tube cooler furnished if required. Various options.
**SIDE LOAD CAPABLE:	No. Contact Cotta for recommendations.
***APPROXIMATE WEIGHT:	900 lbs.

* Flywheel coupling selection requires Cotta technical review and approval.

** Some speed reducers output shafts are suitable for chain or belt side pull drives while others are not. Provide complete application details to Cotta for recommendations and approval.

*** Weight listed is an average. Actual weight can vary substantially with options such as SAE housing size and flywheel coupling choices.



This drawing shows general arrangement and approximate space claim. Do not design or lay out using this drawing. Use only certified drawings provided by Cotta Engineering.

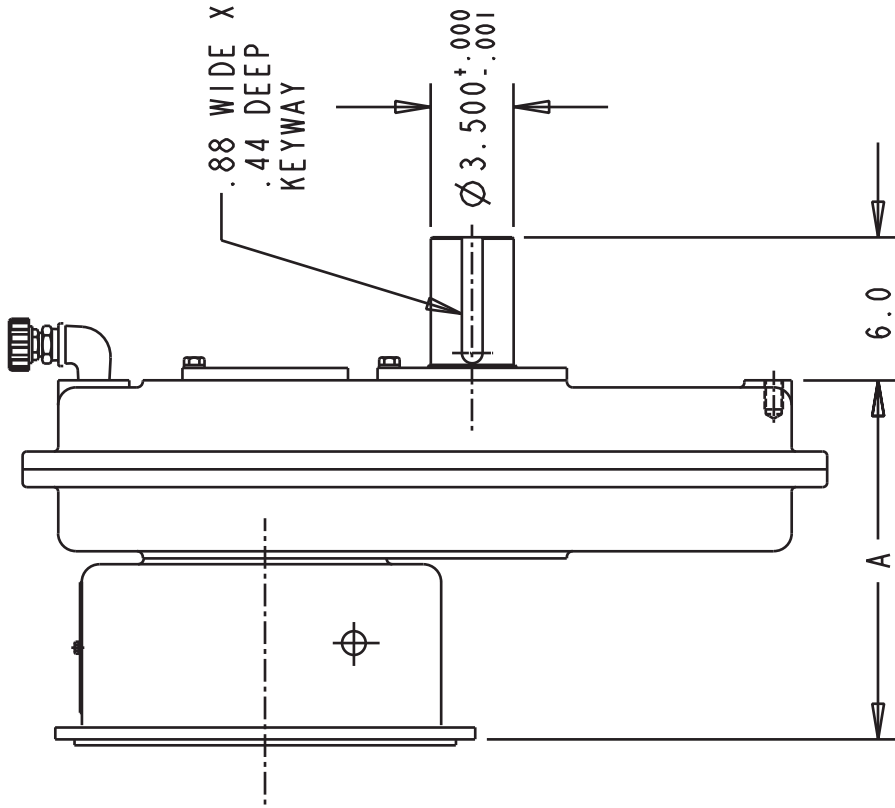
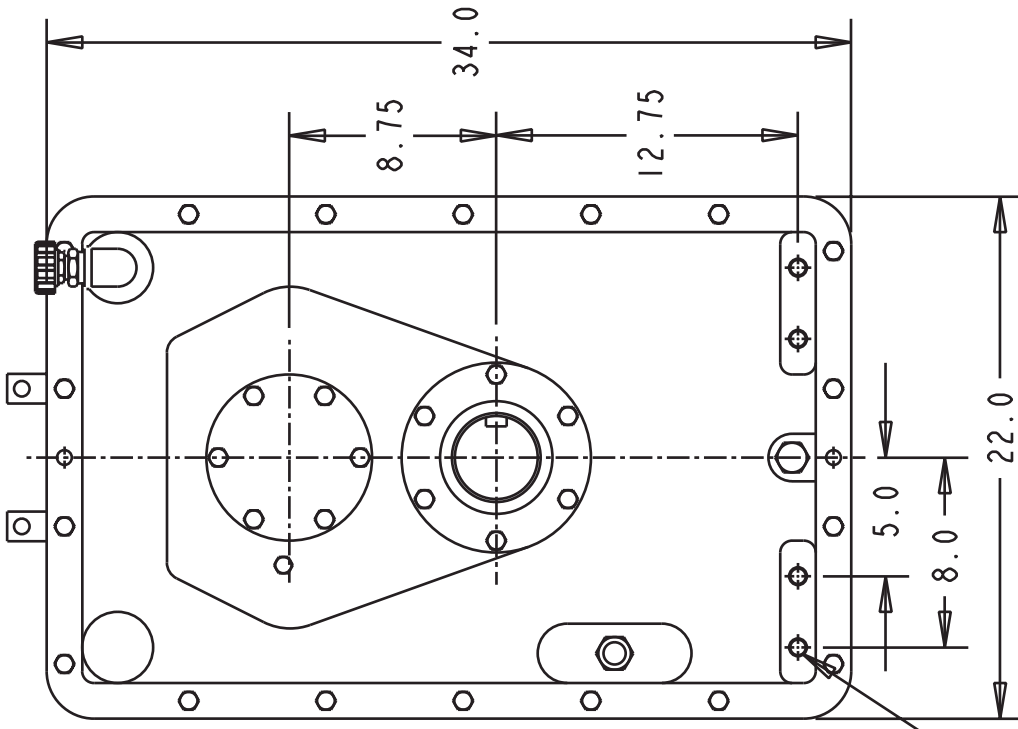

3/4-10 UNC THREAD
TYP (4)
FOR GEARBOX MOUNTING

BELLHSG SAE #	DIM A
#2	15.12
#1	17.00
#0	19.75

SR2030E DRAWING